

INSTALLATION INSTRUCTIONS BUILT-IN CHAR BROILER MODEL B-446

ELECTRICAL

MODEL	VOLTS	WATTS	AMPS PER LINE 3 PHASE			AMPS SINGLE PHASE	FIELD WIRING GAUGE		TEMP. RATING
			L1	L2	L3		3 PHASE	1 PHASE	
B-446	208	5400	11.5	22.4	14.4	28.0	8 AWG Cu	8 AWG Cu	90°C
B-446	240	5400	10.0	19.5	12.5	22.5	8 AWG Cu	8 AWG Cu	90°C

INCH
(MM)

CUTOUT DETAILS

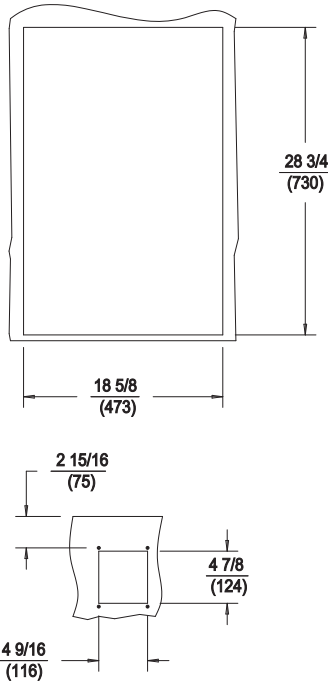

PRODUCT DIMENSIONS

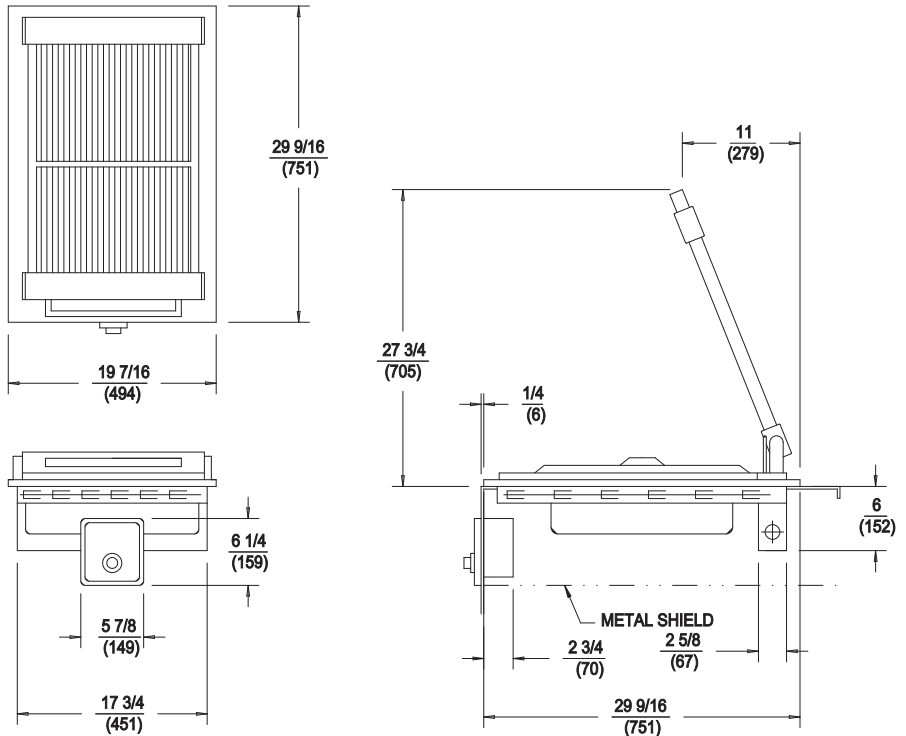

CLEARANCES

MINIMUM CLEARANCE REQUIRED FROM UNIT TO THE NEAREST SURFACE*			
BACK	SIDE	BOTTOM	FRONT
$\frac{7}{8}$ (178)	$\frac{6}{8}$ (152)	$\frac{3}{8}$ (76)	$\frac{5}{8}$ (16)

INSTALLATION INSTRUCTIONS

UNIT MUST BE INSTALLED IN AN ALL METAL COUNTER

THE INSTALLATION OF RECOGNIZED COMPONENT UNITS REQUIRES ADDITIONAL EVALUATIONS TO UNDERWRITERS LABORATORIES STANDARDS.

INSTALLER MUST MEET CONDITIONS OF ACCEPTABILITY OUTLINED BELOW UPON INSTALLATION:

1. This appliance must be installed in an all metal counter with suitable wiring and control enclosures conforming to national and local electrical codes.
2. Electrical component temperatures, including wiring, within and surrounding the appliance must be monitored in the end use installation for suitability.
3. Electrical grounding of all dead metal parts must be reliably connected to the grounding means of the appliance and must comply with requirements outlined in the appropriate Underwriters Laboratories Inc. classification, national and local electrical codes.
4. Increased clearances are required if storage of combustible materials is in close proximity to this appliance.
5. Unit shall be accessible for servicing from bottom.
6. The name/rating plate information shall be accessible.

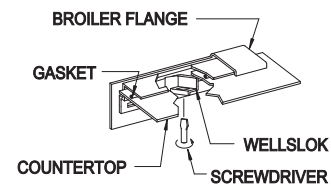

TO FABRICATE AND INSTALL:

1. Lay out cutout dimensions on countertop and control apron as shown in cutout details.
 2. Cut and/or drill holes as required in countertop and apron.
- NOTE: If stiffener is used around perimeter of countertop cut-out, total thickness of stiffener plus countertop cannot exceed $\frac{3}{16}$ ". Also, make certain stiffener design does not interfere with operation of ears on Wellslok flange.
3. Place gasket on underside of broiler flange. Apply a bead of silicone sealant to underside of gasket.
 4. Locate broiler near countertop cutout. Pass control panel through countertop cutout and bring it through control panel cutout on apron. Seat broiler into counter.
 5. From underneath, insert screwdriver into slots on patented Wellslok frame and twist ears clockwise to secure flange tightly to countertop.
 6. Mount control box to apron using screws supplied. Mount control panel to control box.

NOTE: INSTALLATION MUST MEET LOCAL AND NATIONAL ELECTRICAL CODES.