



Job _____ Item No. _____

Modular Dry Well

□MDW100 □MDW200 □MDW300 □MDW400 □MDW500



MDW100
(patent pending)

DESCRIPTION

Wells patent pending dry well units are designed to efficiently hold heated foods at safe serving temperatures with no need for water or drains and are available in 1-5 well versions. Each dry well is designed to hold [1] standard full-size steam table pan up to six [6] inches (152 mm) deep or equivalent fractional pans per well.

SPECIFICATIONS

Wells MDW dry well units are constructed in the U.S.A. with a corrosion-resistant type 430 stainless steel body. The units include factory-attached infinite controls for each individual well. The one [1] and two [2] well models are single [1] phase, but can be converted to three [3] phase. The three [3], four [4], and five [5] well models are three [3] phase and can be field converted to single [1] phase. All units come setup to hard-wire. The standard units use 0.61 kW per well at 208 V and 0.8 kW per well at 240 V. The units are insulated on front, back, sides, and bottom. Units are designed to be top-mounted.

WARRANTY

These units come with a one [1] year warranty for parts and labor.

FEATURES

- Utilizes tubular heating elements and stainless steel fan meaning no need for water or drains
- Modules use less energy translating to operational cost savings
- Each well uses an individual control knob to allow independent control of each section on multiple-well units
- Dry design allows full top-side access to components after installation
- Accommodates one [1] standard full-size steam table pan up to six [6] inches (152 mm) deep pan or equivalent fractional pans per well
- Included Wellslok system securely fastens to metal counters up to 0.25-inch (6 mm) thick
- Built-in high limit switch prevents overheating

OPTIONS & ACCESSORIES

- Extension kit for mounting to wood and plastic countertops
- Adapter tops
 - convert one well to hold two 7 qt. insets [20176]
 - convert one well to hold two 4 qt. and two 2.5 qt insets [20434]
 - convert one well to hold three 4 qt. insets [21615]
 - convert one well to hold one 7 qt. and one 4 qt. inset [21621]
 - convert one well to hold four 2.5 qt. insets [21624]
- Insets
 - 4 qt. round inset with lid [20774]
 - 7 qt. round inset with lid [20587]
 - 11 qt. round inset with lid [20908]
 - 11 qt. round inset with hinged lid [21057]

CERTIFICATIONS



WELLS BLOOMFIELD, LLC • www.wellsbloomfield.com

10 Sunnen Drive • Saint Louis, Missouri 63143

Telephone 888 356 5362 • Fax 314 781 5445

Printed in the U.S.A. • 2M-Z21300 • Rev A • 01.2017

Specifications are subject to change without notice and are not intended for installation purposes. Please refer to the installation instructions for further installation information.



Modular Dry Well

□MDW100 □MDW200 □MDW300 □MDW400 □MDW500

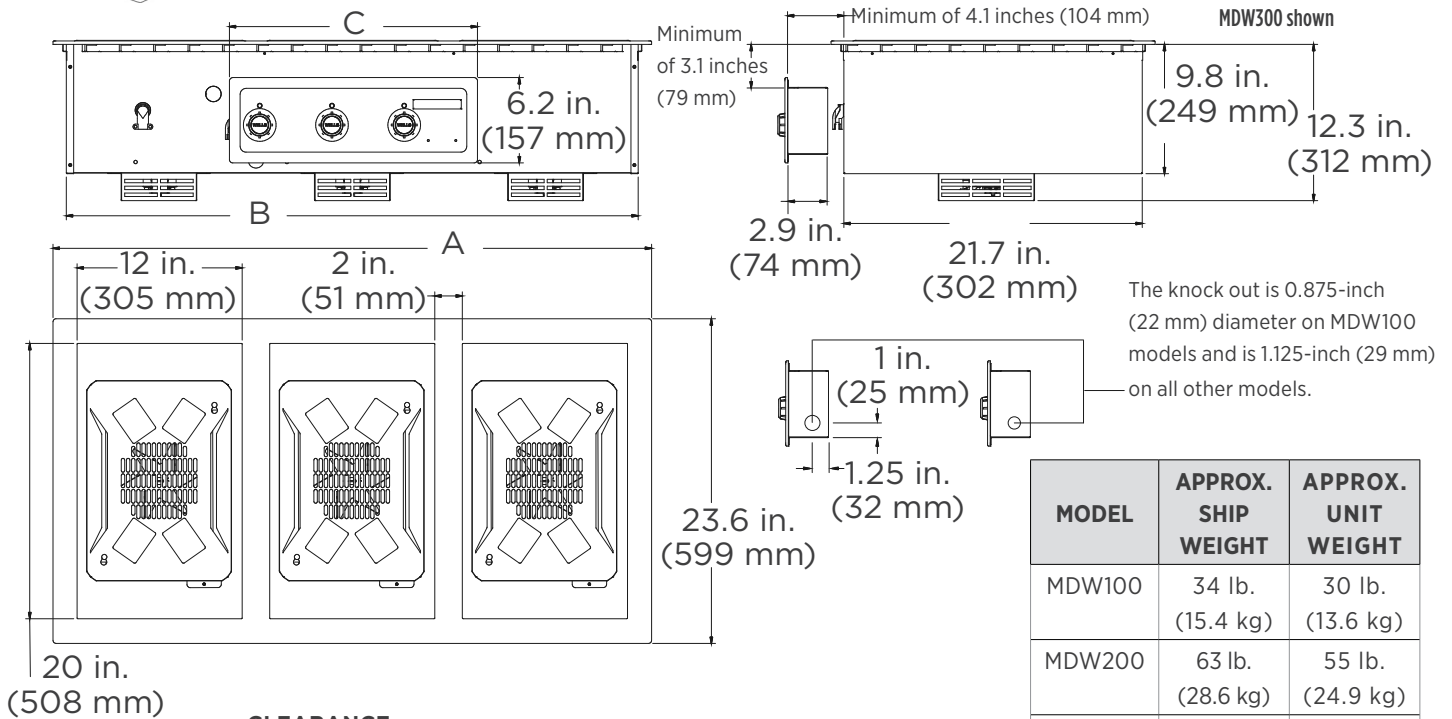

CLEARANCE

Do not install closer than six [6] inches (152 mm) to front wall, one [1] inch (25 mm) to back and side walls, and 6.75 inches (171 mm) to a surface below the unit. If storage is to be used underneath, it is recommended that a baffle be placed 8.5 inches (216 mm) below the unit to avoid contact with elevated temperatures.

MODEL	APPROX. SHIP WEIGHT	APPROX. UNIT WEIGHT
MDW100	34 lb. (15.4 kg)	30 lb. (13.6 kg)
MDW200	63 lb. (28.6 kg)	55 lb. (24.9 kg)
MDW300	160 lb. (72.6 kg)	80 lb. (36.3 kg)
MDW400	185 lb. (83.9 kg)	105 lb. (47.6 kg)
MDW500	210 lb. (95.3 kg)	130 lb. (59 kg)

MODEL	TOP WIDTH [A]	BOTTOM WIDTH [B]	CONTROL WIDTH [C]	DEPTH	HEIGHT BELOW SURFACE	VOLTS, PHASE	AMPS			TOTAL kW
							L1	L2	L3	
MDW100	14.8 in. (376 mm)	13.2 in. (335 mm)	5.9 in. (149 mm)	20 in. (508 mm)	11.9 in. (302 mm)	208, 1Φ 240, 1Φ	2.9			0.61
							3.3			0.8
MDW200	29.5 in. (749 mm)	27.6 in. (701 mm)	14.1 in. (359 mm)	20 in. (508 mm)	11.9 in. (302 mm)	208, 1Φ 240, 1Φ	5.9			1.22
							6.7			1.6
MDW300	43.5 in. (1.1 m)	41.6 in. (1.06 m)	18 in. (457 mm)	20 in. (508 mm)	11.9 in. (302 mm)	208, 3Φ 240, 3Φ	5.1	5.1	5.1	1.83
							5.8	5.8	5.8	2.4
MDW400	57.5 in. (1.46 m)	55.6 in. (1.41 m)	18 in. (457 mm)	20 in. (508 mm)	11.9 in. (302 mm)	208, 3Φ 240, 3Φ	5.1	7.6	7.6	2.44
							5.8	8.7	8.7	3.2
MDW500	71.5 in. (1.82 m)	69.6 in. (1.77 m)	18 in. (457 mm)	20 in. (508 mm)	11.9 in. (302 mm)	208, 3Φ 240, 3Φ	7.6	7.6	10.1	3.05
							8.7	8.7	11.5	4

Due to periodic changes in designs, methods, procedures, policies and regulations, the specifications contained in this sheet are subject to change without notice. While Star Manufacturing exercises good faith efforts to provide information that is accurate, we are not responsible for errors or omissions in information provided or conclusions reached as a result of using the specifications. By using the information provided, the user assumes all risks in connection with such use.



WELLS BLOOMFIELD, LLC • www.wellsbloomfield.com
 10 Sunnen Drive • Saint Louis, Missouri 63143
 Telephone 888 356 5362 • Fax 314 781 5445

Printed in the U.S.A. • 2M-Z21300 • Rev A • 01.2017
 Please refer to the owner's manual for information regarding installation or use.