

BUILT-IN RECTANGULAR FOOD AND LIQUID WARMERS

MODELS HMP-6, HMP-6D

ELECTRICAL

MODEL	VOLTS	WATTS	AMPS	PHASE	FIELD WIRING GAUGE	TEMP. RATING
HMP-6	120	750	6.3	SINGLE	14	90
HMP-6D	120	750	6.3	SINGLE	14	90

CUTOUT DETAILS

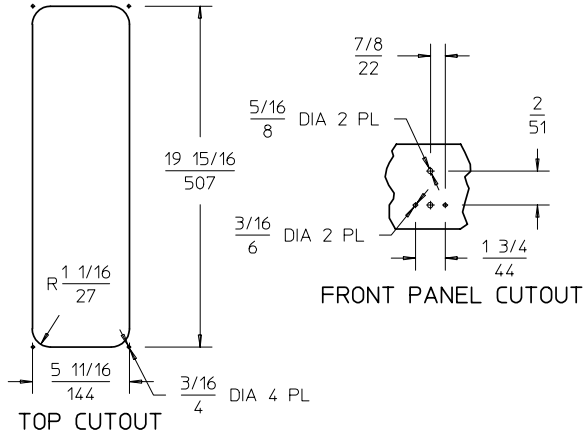

PRODUCT DIMENSIONS

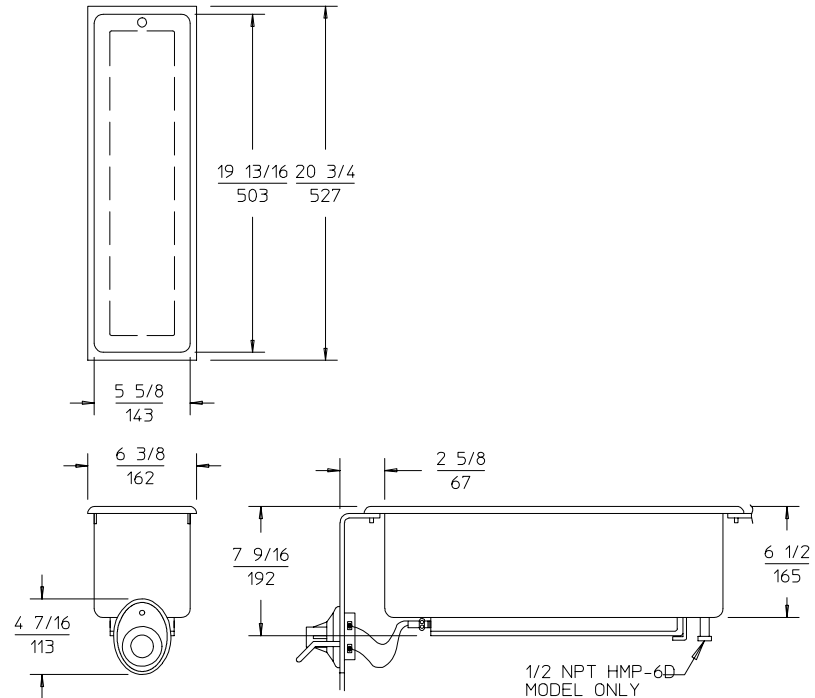

CLEARANCES

SUGGESTED CLEARANCE FROM UNIT TO THE NEAREST SURFACE			
BACK	SIDE	BOTTOM	FRONT
$\frac{1}{(25)}$	$\frac{2}{(51)}$	$\frac{9}{(229)}$	$\frac{2 \frac{5}{8}}{(67)}$

SEE CONDITIONS OF ACCEPTABILITY BELOW

INSTALLATION INSTRUCTIONS

UNIT MUST BE INSTALLED IN AN ALL METAL COUNTER

THE INSTALLATION OF RECOGNIZED COMPONENT UNITS REQUIRES ADDITIONAL EVALUATIONS TO UNDERWRITERS LABORATORIES STANDARDS.

INSTALLER MUST MEET CONDITIONS OF ACCEPTABILITY OUTLINED BELOW UPON INSTALLATION:

1. This appliance must be installed in an all metal counter with suitable wiring and control enclosures conforming to national and local electrical codes.
2. Electrical component temperatures, including wiring, within and surrounding the appliance must be monitored in the end use installation for suitability.
3. Electrical grounding of all dead metal parts must be reliably connected to the grounding means of the appliance and must comply with requirements outlined in the appropriate Underwriters Laboratories Inc. classification, national and local electrical codes.
4. Increased clearances are required if storage of combustible materials is in close proximity to this appliance.
5. Unit shall be accessible for servicing from bottom.
6. The name/rating plate information shall be accessible.
7. For water and waste connections: This appliance is to be installed to comply with applicable federal, state and local plumbing codes.

TO FABRICATE AND INSTALL:

1. Layout cutout dimensions on countertop and apron, shown in cutout details above.
2. Cut and/or drill holes as required in countertop and apron.
3. Do not disconnect control lead wires when installing.
4. To install: locate warmer and control over counter cutout. Pass control through opening.
5. Apply a bead of silicone sealant to gasket on underside of warmer flange, then seat warmer onto countertop. Properly position.
6. From underneath, attach hex nuts (supplied) to corner screws and tighten.
7. Attach control thermostat and pilot light to counter apron.
8. Attach oval panel to counter apron.

NOTE: INSTALLATION MUST MEET LOCAL PLUMBING AND ELECTRICAL CODES.